



模组规格书

SPECIFICATION FOR LCD MODULE

| | |
|-----------------------|-----------------------------------|
| 客户名称(Customer Name) : | |
| 客户料号(Customer P/N.) : | |
| 模组型号(TCC P/N.) : | SYM320240B8V20-5KFM4-B6WIF-T42022 |
| 物料编号(TCC C/N.) : | |
| 文件号(Version No.) : | A1 |
| 日期(Date) : | 2012/11/06 |

| 公司签核 (Signature) | 管理者 (Manager) | 市场 (Sales) | 工程 (Engineering) | 品保 (QA) |
|---------------------|------------------|---------------|---------------------|------------|
| | | | | |

| | |
|-----------------------------|--|
| 客户确认 (Customer approval) | |
|-----------------------------|--|

- ※ 本公司承诺所销售产品的品质与所送样品一致
We promise that our products conform to the sample furnished in quality,
- ※ 若对试样产品的品质有特殊要求，请与本公司销售工程师联系。
In case of any special requirement on the quality, please feel free to contact our sales engineers.
- ※ 感谢您给予本公司送样承认的机会，烦请将此表签回本公司便于归档。
Thanks for awarding this opportunity of sample approval, please return this form to us for filing after authentication.

目 录 Contents

| | | |
|-----------|---------------------------------------|-------|
| 1 · 模组规格 | Functions & Features····· | 2 |
| 2 · 机械尺寸 | Mechanical specifications····· | ..2 |
| 3 · 原理框图 | Block diagram····· | 2 |
| 4 · 模组外形图 | Dimensional Outline····· | .3 |
| 5 · 接口定义 | Pin description····· | 3~4 |
| 6 · 极限参数 | Absolute Maximum limit····· | ..4 |
| 7 · 电性参数 | Electrical characteristics····· | 5 |
| 8 · 光电特性 | Electrol-Optical characteristics····· | 5~6 |
| 9 · 时序特性 | Timing Characteristics····· | 7~8 |
| 10 · 品质保证 | Quality Assurance····· | 10~15 |
| 11 · 注意事项 | Precaution for using LCD/LCM····· | 16~17 |

版本记录 Revision History

| 版本 Revision# | 日期 Date | 描述 Description | 编制 Organizer |
|-----------------|------------|-------------------|-----------------|
| A0 | 2005-5-6 | 初始 Original | keguodong |
| A1 | 2012/11/06 | EMC 改进 | LSS |

1、 模组规格 Functions & Features

| | | | |
|----------------------|-----------------------------------------------|-------------------|---------------|
| 视角 Viewing direction | 6:00 | 工艺方式: SMT | |
| LCD 模式 LCD mode | FFSTN, B-W 黑白膜 , Negative 负显, Transmissive 全透 | | |
| 驱动方式 Driving scheme | 占空比(Duty) : 1/240 偏压比(Bias) : 1/17 | | |
| 背光颜色 Backlight color | 白色 White, CCFL | | |
| LCM 驱动电压(VDD) | 5.0V | LCD 电压(VLCD) | 23.5V(Ref.)上下 |
| 工作温度 Operation temp | -20~70°C | 储存温度 Storage temp | -30~80°C |

注: 1, 此屏电压还有 3.3V 可选; 2, 5V 屏亦可与 3.3VMCU 数据匹配; 3 ,LCD 及背光也有多种选择.

2、 机械尺寸 Mechanical specifications

| 项目 Item | 尺寸 Dimension | 单位 Unit |
|---------------------------|---------------------------------|---------|
| 显示容量 Number of Characters | 320x240 | Dots |
| 模组尺寸 Module size | 167.0(L)* 109.0 (W)*11.0 (H)max | mm |
| 可视区域 Viewing area | 122.0 (L)*92.0 (W) | mm |
| 点间距 Dot pitch | 0.36(L)*0.36(W) | mm |
| 点大小 Dot size | 0.33(L)*0.33(W) | mm |

3、 原理框图 Block diagram

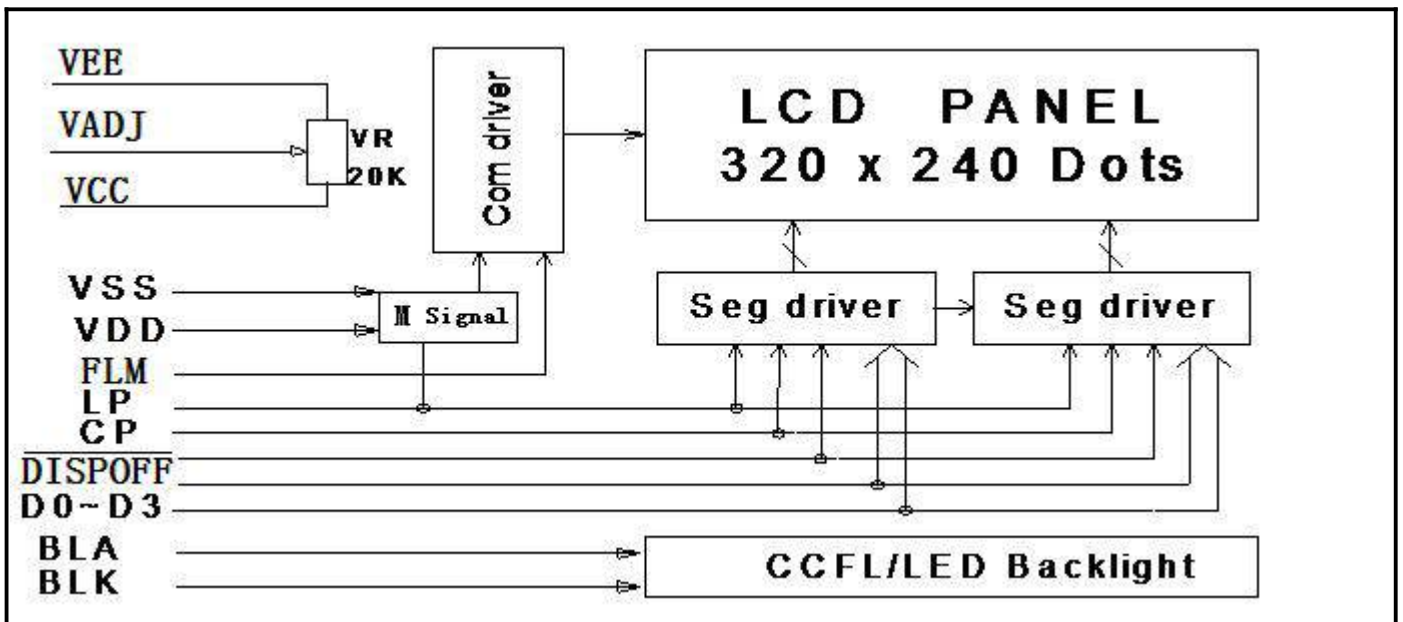

* Note: when the temperature exceed 25°C, the approved current decrease rate for Backlight change as

the temperature increase is: $-0.36\text{mA} \cdot 12/^\circ\text{C}$ (below 25°C , the current refer to constant, which would not hange with temperature).

4、模组外形图 Dimensional outline

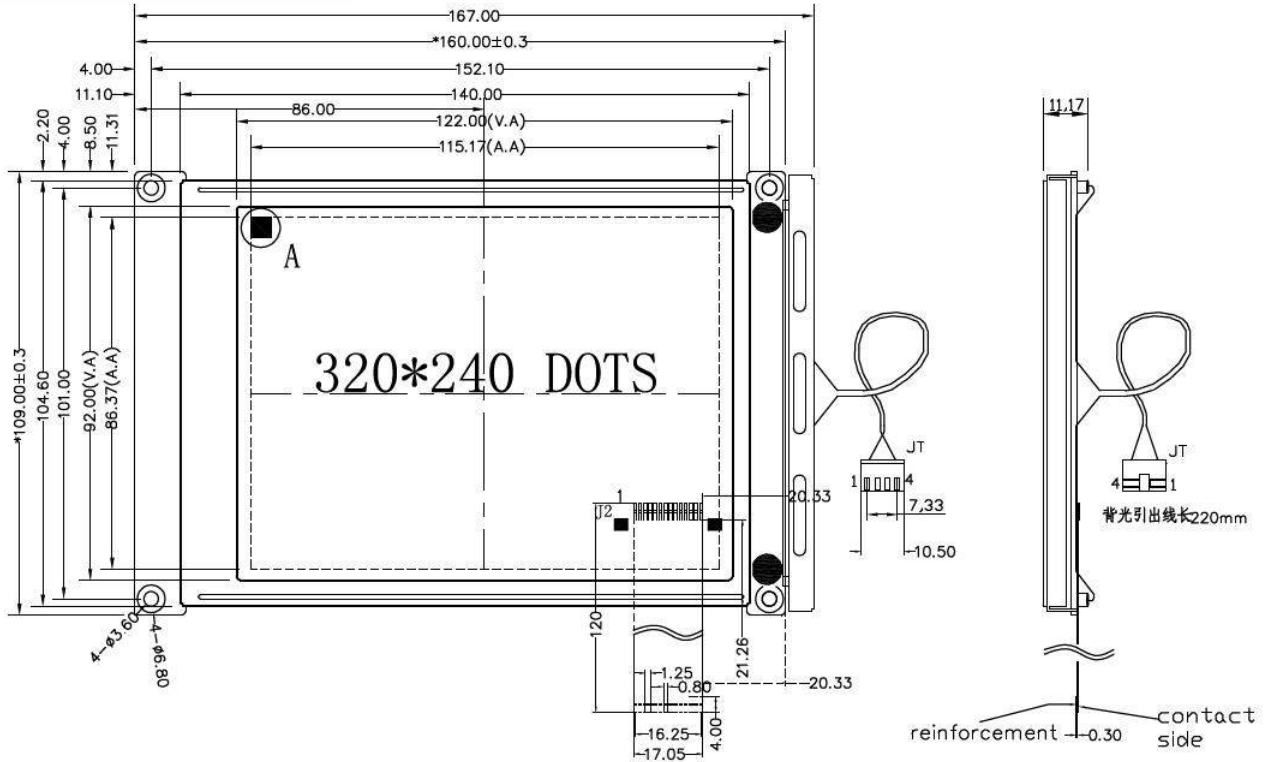

5、接口定义 Pin description

J2:PH1.25, J3:PH2.54 接口定义:

| 项目 Item | 标号 Symbol | 描述 Function |
|---------|-----------|---------------------------------|
| 1~4 | D0~D3 | Data bus lines(数据线) |
| 5 | DISP | Display ON/OFF (显示开关, 高电平开低电平关) |
| 6 | FLM | Frame signal(每一帧的开始) |
| 7 | NC | No signal(空脚) (屏带 M 信号) |
| 8 | LP | Data Latch Pulse(数据锁存信号) |

| | | |
|----|------|---------------------------------------------------------------------------------|
| 9 | CP | Data shift Pulse(数据移位信号) |
| 10 | VCC | Power supply for Logic 电源正(+5V) |
| 11 | VSS | Power Ground 电源地(0V) |
| 12 | VEE | Power supply for the LCD drive 对比度电源端（负压,-21.5V）。 （如果屏带负压电源电路，此接口即为 VOUT） |
| 13 | VADJ | Power supply for the LCD drive 对比度调节输入端(负压,-18.5V 左右，屏显内容多少电压需调整在最佳位置上)（VO） |
| 14 | Fgnd | 铁框地 |

6、极限参数 Absolute Maximum limit

| 项目 Item | 符号 Symbol | 最小值 MIN | 最大值 MAX | 单位 Unit |
|----------------------------------|--------------|------------|------------|------------|
| 驱动电压 Supply Voltage for Logic | VDD | -0.3 | 7.0 | V |
| LCD 电压 Supply Voltage for LCD | VLCD | -0.3 | 23.5 | V |
| 输入电压 Input Voltage | Vin | -0.3 | VDD+0.3 | V |
| 工作温度 Operating Temperature | Top | -20 | 70 | °C |
| 储存温度 Storage Temperature | Tstr | -30 | 80 | °C |

7、电性参数 Electrical characteristics

| 项目 Item | 符号 Symbol | 条件 Condition | 最小值 MIN | 典型值 Typ | 最大值 MAX | 单位 Unit |
|----------------------------------|--------------|-----------------|------------|------------|------------|------------|
| 逻辑电压 Supply Voltage for Logic | VDD-VSS | Ta = 25°C | 4.75 | 5.0 | 5.25 | V |
| 输入高电压 Input High Voltage | VIH | Ta = 25°C | 0.7VDD | --- | VDD | V |
| 输入低电压 Input Low Voltage | VIL | Ta = 25°C | 0 | --- | 0.3VDD | V |
| 输出高电压 Output High Voltage | VOH | Ta = 25°C | 2.4 | --- | --- | V |

| | | | | | | |
|-----------------------------|-----|-----------|-----|-----|-----|----|
| 输出低电压 Output Low Voltage | VOL | Ta = 25°C | --- | --- | 0.4 | V |
| 模块电流 Supply Current | IDD | Ta = 25°C | --- | 16 | | mA |

8、光电特性 Electro-Optical characteristics

调节对比度电位器接到接口上，一头接到 VEE，另一头接 VCC，中心抽头接到 VADJ 上。
VR=20K,液晶屏上也预留有电位器 VR1 供选择。

Example of Power Supply

It is recommended to apply a potentiometer for the contrast adjust due to the tolerance of the driving voltage and its temperature dependence.

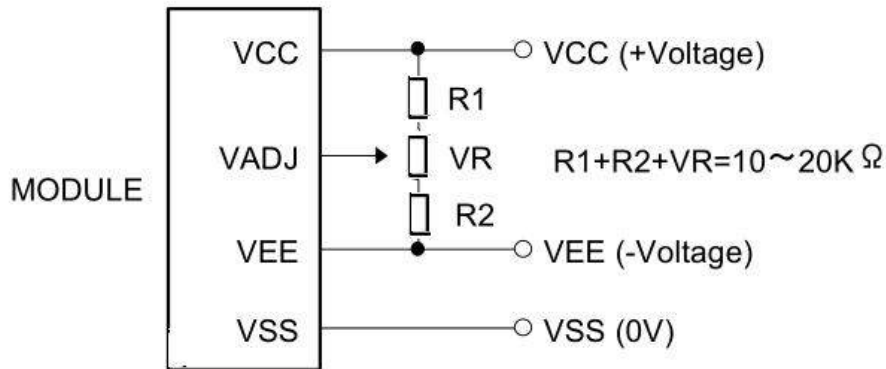

| 项目 Item | 标号 Symbol | 条件 Condition | 最小 MIN | 典型 Typ | 最大 MAX | 单位 Unit |
|-------------------------------|--------------|-----------------|-----------|-----------|-----------|------------|
| 工作电压(负压) Operating Voltage | VADJ | Ta = -20°C | --- | --- | --- | --V |
| | | Ta = +25°C | -18.0 | -18.5 | -19.3 | |
| | | Ta = +70°C | --- | --- | --- | |
| 响应时间 Response time | Tr | Ta = 25°C | --- | 180 | --- | ms |
| | Tf | | --- | 320 | --- | ms |
| 对比度 Contrast Ratio | Cr | Ta = 25°C | --- | 5 | --- | --- |
| 视角范围 Viewing angle range | θ | Cr ≥ 2 | -30 | --- | +40 | deg |
| | Φ | | -30 | --- | +30 | deg |

Definition of Operation Voltage (Vop)

Definition of Response Time (Tr, Tf)

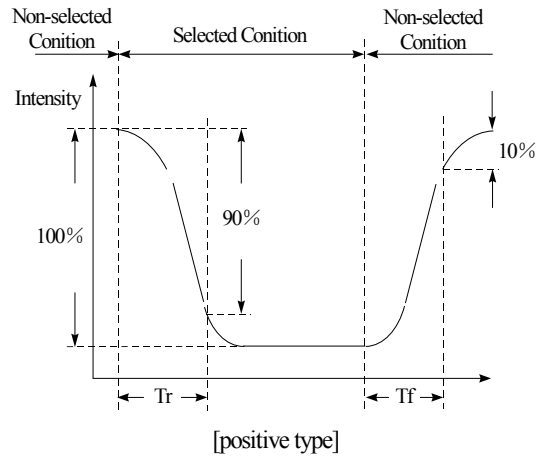
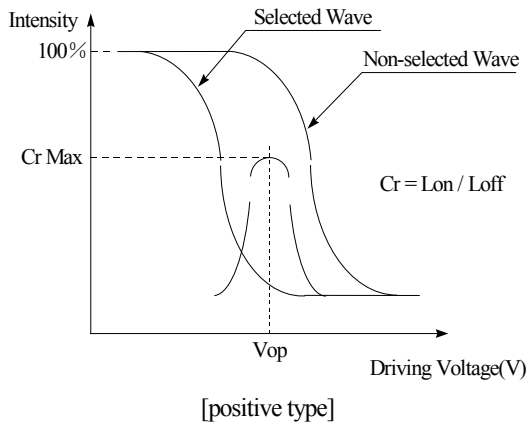

Conditions :

| | |
|-------------------------|---------------------------------------------------------------|
| Operating Voltage : Vop | Viewing Angle(θ , φ) : 0° , 0° |
| Frame Frequency : 64 HZ | Driving Waveform : 1/N duty , 1/a bias |

Definition of viewing angle(CR \geq 2)

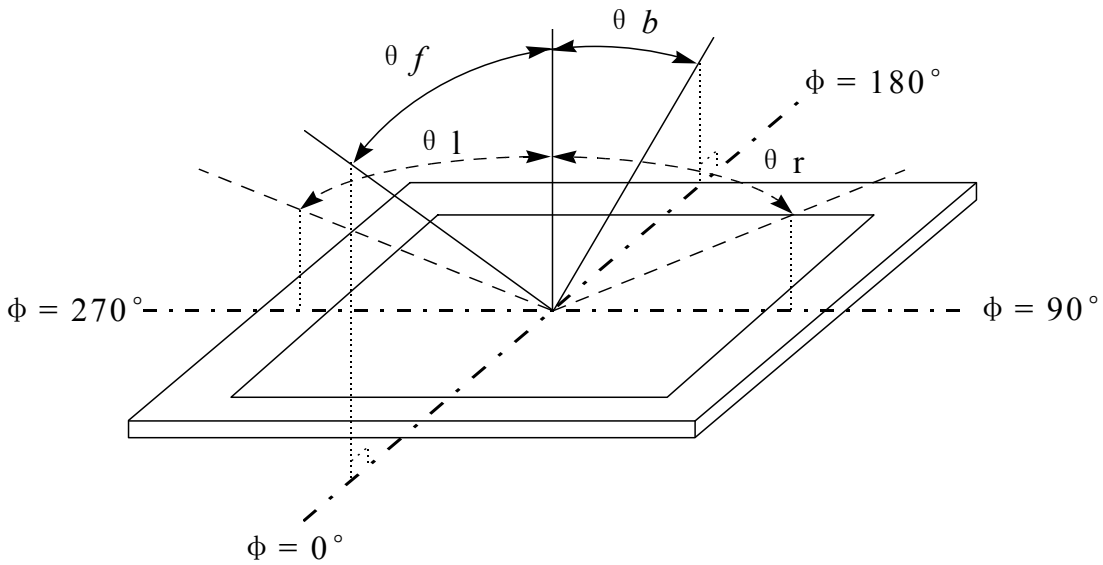

9、时序特性 Timing characteristics

AC Characteristics

$V_{CC}=5.0V \pm 10\%$

| Parameter | Symbol | Min. | Max. | Units |
|------------------------|-------------|------|--------|-------|
| CP Frequency | f_{CP} | — | 6.0 | MHz |
| Clock Pulse Width | t_{WC} | 50 | — | ns |
| Load Pulse Width | t_{WL} | 63 | — | ns |
| Data Setup Time | t_{SETUP} | 30 | — | ns |
| Data Hold Time | t_{HOLD} | 30 | — | ns |
| Clock Pulse Setup Time | t_{CL} | 80 | — | ns |
| Clock Pulse Hold Time | t_{LC} | 110 | — | ns |
| Rise/Fall Time | t_r, t_f | — | Note 1 | ns |
| FLM Setup Time | t_{FDS} | 100 | — | ns |
| FLM Hold Time | t_{FDH} | 100 | — | ns |

Note 1: The rise and fall times (t_r, t_f) must satisfy the following relationships (① and ②).

$$\text{① } t_r, t_f < \frac{1}{2f_{CP}} - t_{WC}$$

$$\text{② } t_r, t_f < 50 \text{ ns}$$

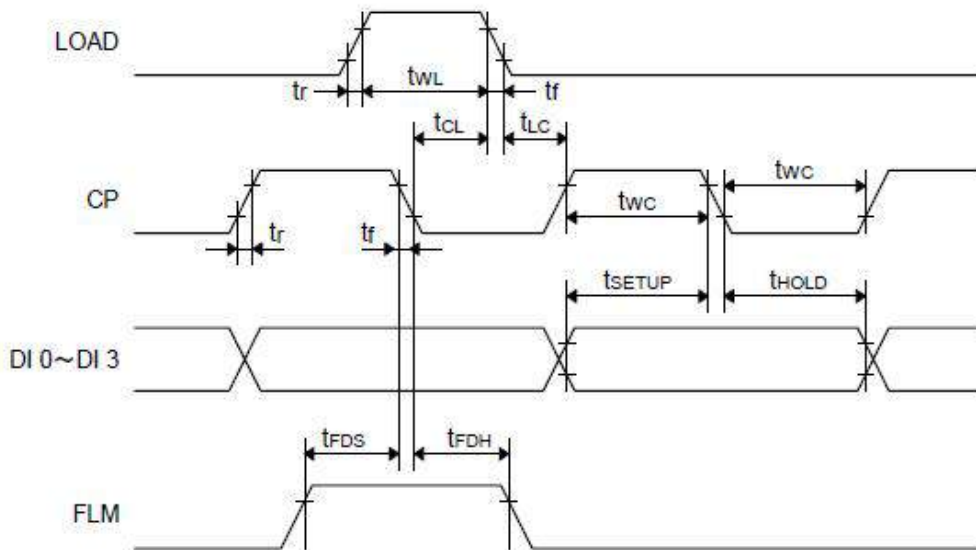

This module contain these capacitors. Please be careful about timing characteristics.

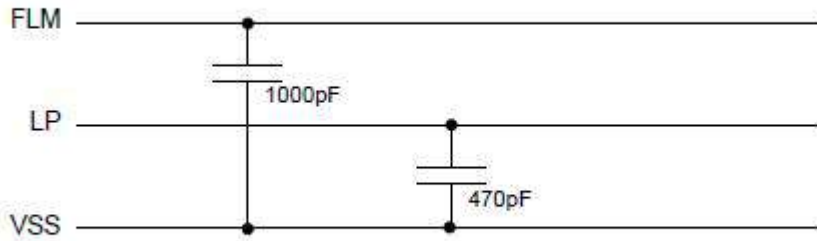

Timing Chart

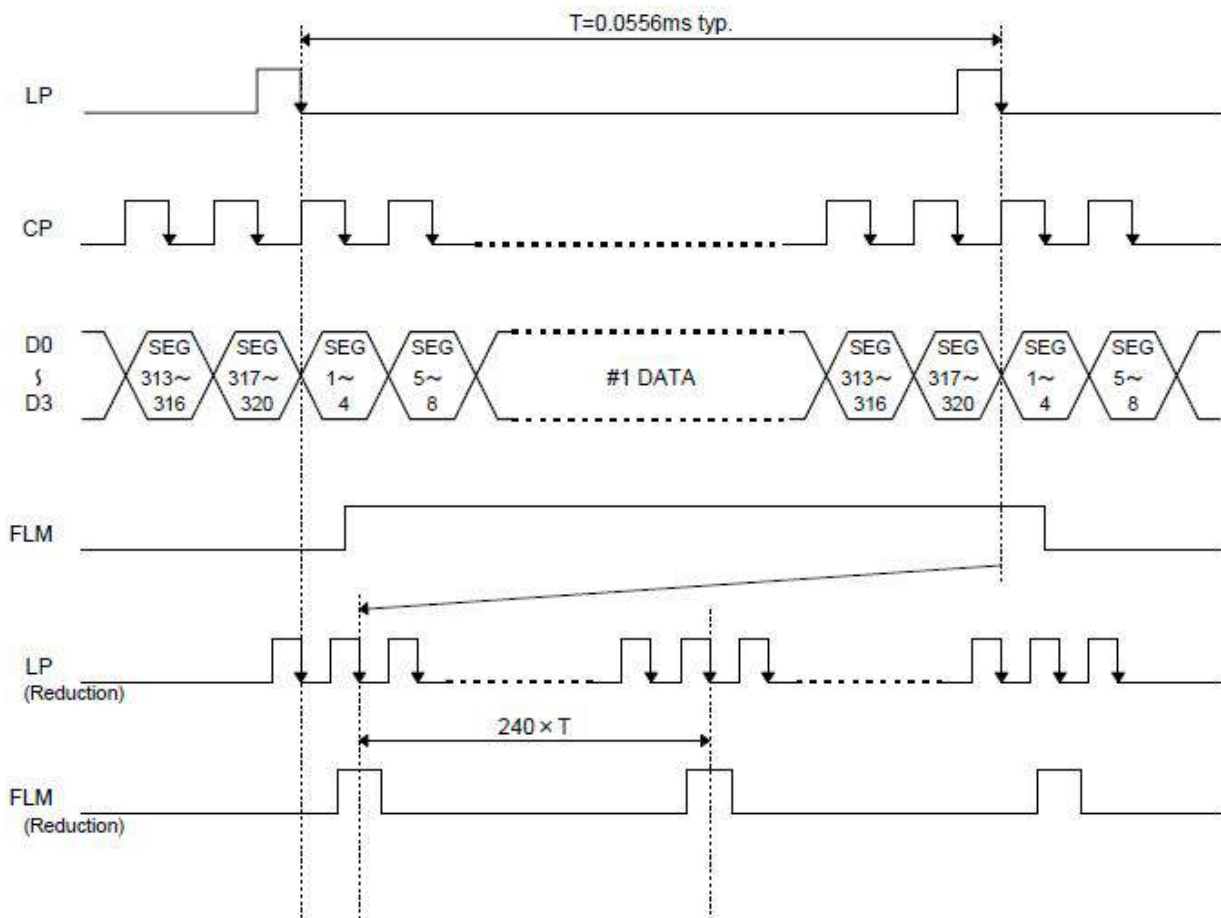

Comparison of Display and Data

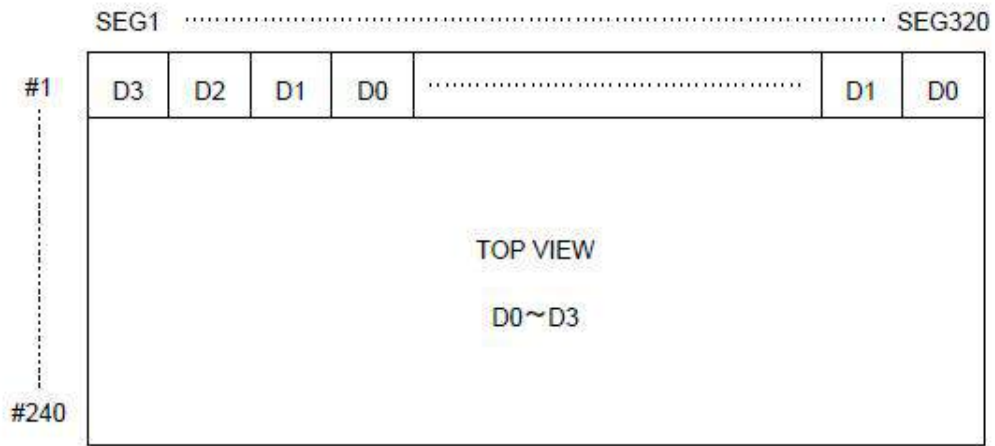

Power Supply ON/OFF Sequence

ON Sequence

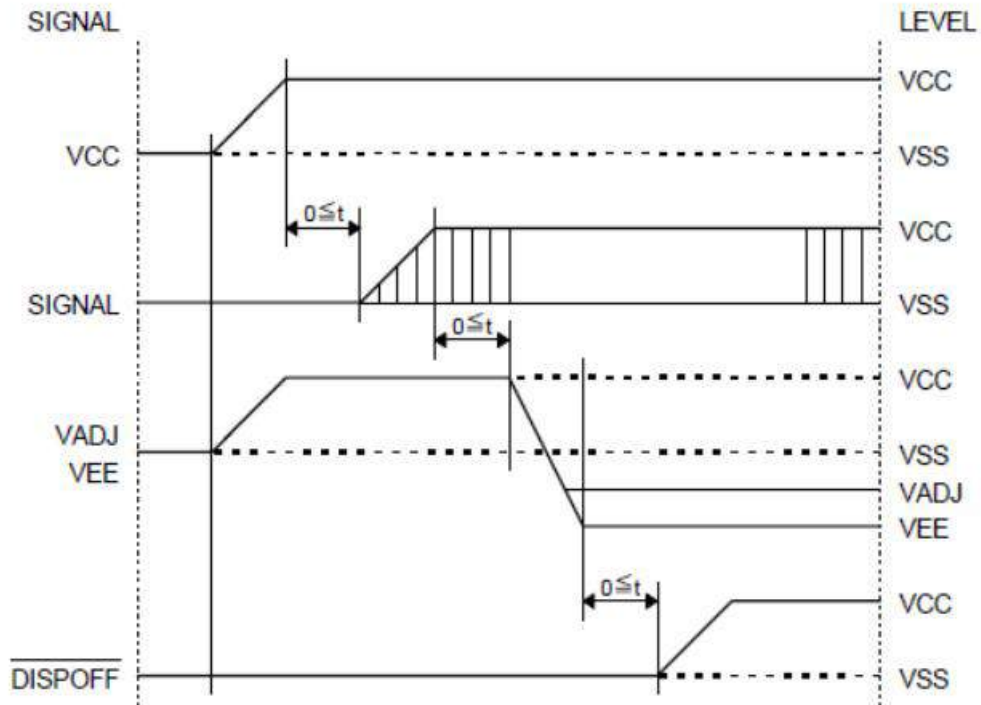

OFF Sequence

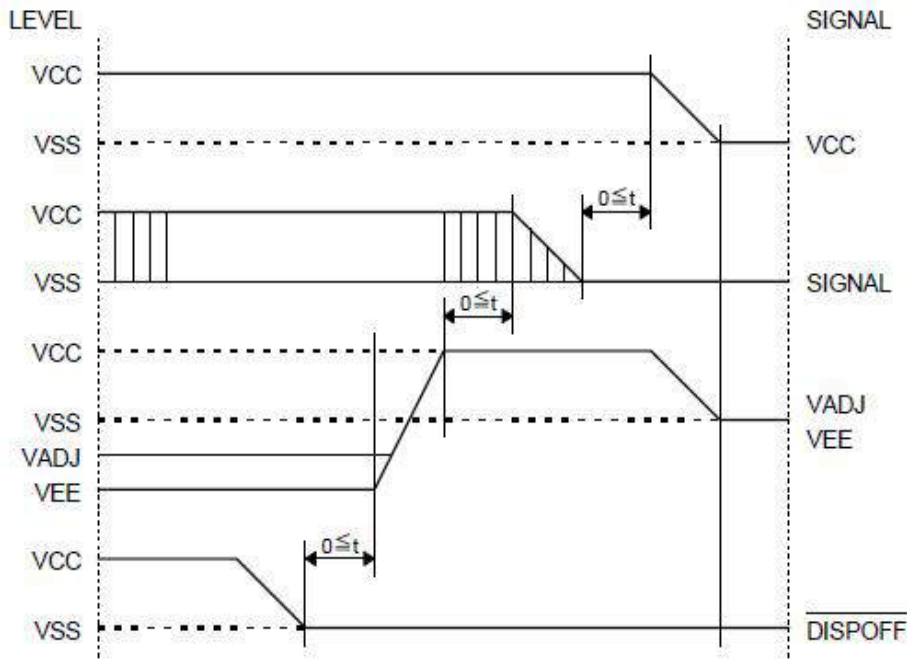

Please maintain the above sequence when turning on and off the power supply of the module. If DISPOFF is supplied to the module while internal alternate signal for LCD driving (M) is unstable, DC component will be supplied to the LCD panel. This may cause damage the LCD module.

10. 品质保证 Quality Assurance

•Our company is qualified through ISO9001:2008 (Certificate NO.: 04910Q10923R0S). Our production plant has stringent quality control to guarantee absolute product quality. release and acceptance of finished LCM products in order to guarantee the quality required by the customer.

1 · Scope

The criteria are applicable to all the LCM products manufactured by TCC, either supplied alone or embedded in or integrated with other components.

2 · Inspection Apparatuses

Function testers, vernier calipers, microscopes, magnifiers, ESD wrist straps, finger cots, labels, ovens for high-low temperature tests, refrigerators, constant voltage power supply (DC) , desk lamps, etc.

3 • Reference Standards

- 3.1.1 GB/T 1619.96 Test Methods for TN LCD.
- 3.1.2 GB/T 12848.91 General Specifications for STN LCD.
- 3.1.3 GB2421-89 Basic Environmental Test Procedures for Electrical and Electronic Products
- 3.1.4 IPC-A-610C Acceptance Condition for Electrical Assemblies.
- 3.1.5 IEC-61000-4-2 Electrostatic Discharge immunity Tests
- 3.1.6 CISPR 22 Class B Conductive & Radiation limits

4 • Inspection Conditions and Inspection Reference

- 4.1 Cosmetic inspection: shall be done normally at $25\pm 5^{\circ}\text{C}$ of the ambient temperature and $45\pm 20\%\text{RH}$ of relative humidity, under the ambient luminance greater than $300\text{cd}/\text{cm}^2$ and at the distance of 30cm apart between the inspector's eyes and the LCD panel and normally in reflected light. For back-lit LCMs, cosmetic inspection shall be done under the ambient luminance less than $100\text{cd}/\text{cm}^2$ with the backlight on.
- 4.2 The LCM shall be tested at the angle of 45° , left and right, and $0-45^{\circ}$, top and bottom (for STN LCM, at $20-55^{\circ}$) .

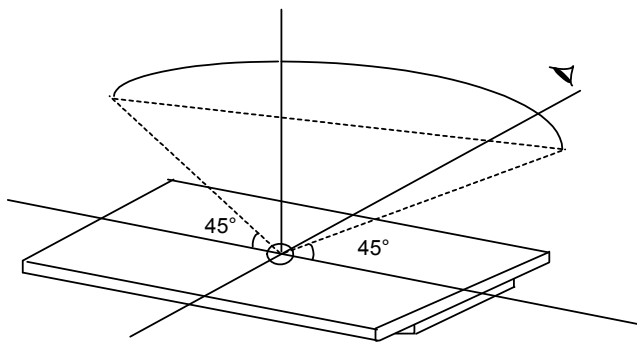

4.3 Definition of VA

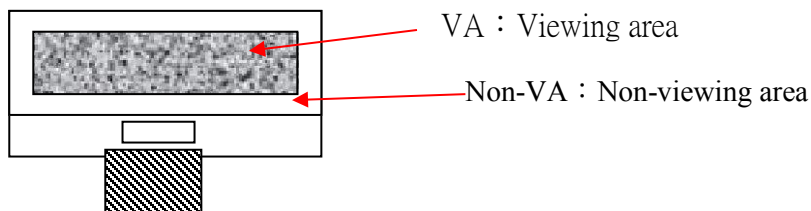

- 4.4 Inspection with naked eyes (exclusive of the inspection of the physical dimensions of defects carried out with magnifiers) .

4.5 Electrical properties

Inspection with the test jigs against the product specifications or drawings; display contents and parameters shall conform to those of the product specifications and the display effect to the sample.

4.5.1 Test voltage (V) :

4.5.1.1 (Determined) according to the operating instruction of test jigs assuming the external circuit can be adjusted unless the customer otherwise specifies driving voltage(s). (Display) effects are controlled within the specified range of voltage variation (If no specific requirements, display effects are controlled at $V_{op} = 9V$ or $V_{op} \pm 0.3V$ when V_{op} is below 9V; if V_{op} is above 9V, display effects are controlled at $V_{op} \pm 0.3\%$ at least). For display products with the customer-specified fixed V_{op} , display effects are controlled by adjusting the internal circuit; if necessary, acceptable limit samples shall be built.

4.5.2 Current Consumption (I) : refer to approved product specifications or drawings.



5 • Defects and Acceptance Standards

5.1 Dimensions : the outline dimensions and the dimensions that could influence the assembly at the customer’ s side shall conform to those on the approved drawings.

5.2 Main Defects – Functionality Tests:

| No. | Item | Description | MAJ | MIN | Acceptance Criteria |
|-------|----------------------|--------------------------------------------------------------------------------------------------------------------------------------------------------------------------------------------|-----|-----|-------------------------------------------|
| 5.2.1 | Missing Segments | Missing segments or dots caused by broken contact(s), loose connection or an internal open circuit.  | √ | | Rejected |
| 5.2.3 | No display /Inaction | No segments, icons or graphics are displayed when the LCM is connected correctly. | √ | | Rejected |
| 5.2.4 | Mis-Display | Display pattern is deformed or jumbled-up under the normal scanning procedure. | √ | | Rejected |
| 5.2.5 | Wrong viewing angle | When powered up, the viewing angle at which the display is at its clearest is different from the required viewing angle or that of the approved samples.) | √ | | Rejected |
| 5.2.6 | Dim or Dark Display | Overall contrast is either too dark or too dim under normal operation. | √ | | If out of the voltage tolerance, Rejected |

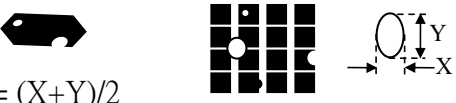
SPECIFICATION FOR LCM MODULE

| | | | | | |
|--------|----------------------------------|-----------------------------------------------------------------------------------------------------------------------------------------------------------------------------------------------------------------------------------------------------------------------------|---|---|----------------------------------------------------------------------------------------------------|
| 5.2.7 | Slow response | Local response time varies when LCM is turned on or off. | ✓ | | Rejected |
| 5.2.8 | Extra segments, rows, or columns | Icons, traces, rows or columns that should not appear on the LCD screen and caused by LCD panel misalignment or insufficient corrosion. | | ✓ | Refer to dot/line standard |
| 5.2.9 | Dim segment | Under the normal voltage, the contrast of vertical and horizontal segments is uneven. | | ✓ | Reject or refer to samples |
| 5.2.10 | PI black/white spots | Partial black and white spots visible when changing display contents due to defective PI layer. | | ✓ | refer to the spot/line criteria for the visible spots when display image remains still; others OK. |
| 5.2.11 | pinhole/white spots | Deformed patterns appearing when LCD is turned on caused by missing ITO.  $d = (X+Y)/2$ | | ✓ | refer to spot/line standard |
| 5.2.12 | Pattern distortion | Segment is either wider, narrower or deformed than the specified, caused by panel misalignment, resulting in unwanted heave(s) or missing: $ a-b \leq 1/4W$ (W is the normal width)  | | ✓ | Acceptable $ a-b > 1/4W$, rejected |
| 5.2.13 | High current | LCM current is larger than the designed value. | | ✓ | Rejected |

5.3 LCD Visual Defects

5.3.1 Spot defect (defined within VA, spots out of VA do not count.)

| Defect | Average diameter (d) | Acceptable quantity | MAJ | MIN |
|---------------------------------------------------------------------------------------------|----------------------|---------------------|-----|-----|
| Spot defect (black spot, foreign matter, nick, scratches, including LC mis-orientation.) | $d \leq 0.2$ | 3 | | ✓ |
| | $0.2 < d \leq 0.25$ | 2 | | |
| | $0.25 < d \leq 0.30$ | 1 | | |

5.3.2 Line defects (defined within VA; those out of VA do not count.)

| Defect | Length(L) | Width(W) | Acceptable quantity | MAJ | MIN |
|--------------------------------------------------------------------------------------------------------------------------------------|------------|-------------|---------------------|-----|-----|
| line defects (scratches, linear foreign matter)  | ≤ 5.0 | ≤ 0.02 | 3 | | √ |
| | ≤ 3.0 | ≤ 0.03 | 3 | | |
| | ≤ 3.0 | ≤ 0.05 | 1 | | |
| note : 1.If the width is bigger than 0.1mm, it shall be treated as spot defect. | | | | | |

5.3.3 Polarizer air bubble (defined within VA; those out of VA do not count.)

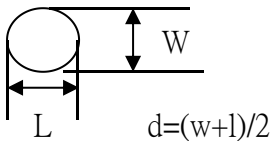
| Defect | Average diameter (d) | Acceptable quantity | MAJ | MIN |
|-----------------------------------------------------------------------------------------------------------------------------------|------------------------|---------------------|-----|-----|
| Polarizer air bubble, Concave-Convex dot.  | $d \leq 0.3$ | 3 | | √ |
| | $0.3 < d \leq 0.5$ | 2 | | |
| | $0.5 < d \leq 0.8$ | 1 | | |

5.4 Backlight

| No. | Item | Description | MAJ | MIN | Accept standard |
|-------|------------------------------------|-------------------------------------------------------------------------------------------------------------------------------------------------------------------------------------|-----|-----|-----------------------------|
| 5.4.1 | Backlight not working, wrong color | / | √ | | Rejected |
| 5.4.2 | Color deviation | When powered on, the LCD color differs from that of the sample and is found after testing not conforming to the drawing. | | √ | Refer to sample and drawing |
| 5.4.3 | Brightness deviation | When powered on, the LCD brightness differs from that of the sample and is found after testing not conforming to the drawing; or if conforming to the drawing but over $\pm 30\%$. | | √ | Refer to sample and drawing |
| 5.4.4 | Uneven brightness | When powered on, the LCD brightness is uneven on the same LCD and out of the specification of the drawing. | | √ | Refer to sample and drawing |
| 5.4.5 | Spot/line scratch | Appearance of spot or line scratches on the LCD when turned on. | | √ | Refer to 6.3.1/6.3.2 |

5.5 Metal frame (Metal Bezel)

| No. | Item | Description | MAJ | MIN | Accept |
|-----|------|-------------|-----|-----|--------|
| | | | | | |

SPECIFICATION FOR LCM MODULE

| | | | | | t standa rd |
|-------|-----------------------------------------------------------------|-----------------------------------------------------------------------------------------------------------------------------------------------------------------------------------------------------------------------------------------------------------------------------------------------------------------------------------------------------------------------------------------------------------------------------------------------|---|---|-------------------|
| 5.5.1 | Material/surface treatment | Metal frame/surface treatment do not conform to the specifications. | √ | | Reject ed |
| 5.5.2 | Tab twist inconformity/ Tab not twisted | Wrong twist method or direction and twist tabs are not twisted as required. | √ | | Reject ed |
| 5.5.3 | Oxidization, chapped paint, discoloration, dents, and scratches | Oxidation on the surface of the metal bezel ; the quantity of spot defect (chapped front surface paint and substrate-exposing scratches) ≤0.8mm exceeds 3; the quantity of linear defects with the length ≤5.0mm and width ≤0.05mm exceeds 2; the quantity of spot defect (front dent, bubble, side surface chapped paint and substrate-exposing scratches)≤1.0mm exceeds 3; the quantity of linear defects with the width ≤0.05mm exceeds 3. | | √ | Reject ed |
| 5.5.4 | Burr | Burr(s) on metal bezel is so long as to get into viewing area. | | √ | Reject ed |

5.6 SMT (Refer to IPC-A-610C if not specified)

| No. | Item | Description | MAJ | MIN | Accept standard |
|-------|--------------------------|---------------------------------------------------------------------------------------------------------------------------------------------------------------------------------------------------------------------------------|-----|-----|-----------------|
| 5.6.1 | Soldering solder defects | Cold, false and missing soldering, solder crack and insufficient solder dissolution. | | √ | Rejected |
| 5.6.2 | Solder ball/splash | Solder ball/tin dross causing short at the solder point. | | √ | Rejected |
| 5.6.3 | DIP parts | Floated or tilted DIP parts , keypad , connectors. | | √ | Rejected |
| 5.6.4 | Solder shape | The welded spot should be concave and excessive or insufficient solder or solder burr on the welded spot must be rejected. | | √ | Rejected |
| 5.6.5 | Component pin exposure | For the DIP type components, 0.5~2mm component pin must be remained after cutting the soldered pin, and the solder surface should not be damaged nor should the component pin is fully covered with solder; otherwise rejected. | | √ | Reject |

| | | | | | |
|-------|-----------------|--------------------------------------------------------------------------------------------------------------------|--|---|--------|
| 5.6.6 | Poor Appearance | Caused by yellow-brown or black solder flux or resin or the white mist at the solder point caused by PCB cleaning. | | √ | reject |
|-------|-----------------|--------------------------------------------------------------------------------------------------------------------|--|---|--------|

6 · Reliability test

Notes : ①Reliability tests shall be done as required by the customer if they inform TCC of their special requirements when starting a project.

②Storage test at high-low temperature and functionality test shall be done with reference to the specified temperature range.

③Test conditions shall be controlled at the permissible tolerance of $\pm 5^{\circ}\text{C}$.

7 · Packing

Guarantee to offer ESD shield bag to protect the product from electrostatic or magnetic interference

| Test item | Condition | Time(hrs) | Acceptance standard |
|----------------------|--------------------------------------------------|-----------|--------------------------------------------------------------|
| High Storage Temp. | 80°C | 120 | Functions and appearance are qualified before and after test |
| High Operating Temp. | 70°C | 120 | |
| Low Storage Temp. | -20°C | 120 | |
| Low Operating Temp. | -30°C | 120 | |
| Temp& Humidity Test | 40°C/ 90%RH | 120 | |
| Thermal Shock | -20°C ← 25°C → +70°C (30 min ← 5 min → 30min) | 10 cycles | |

during delivery

8 · Others

8.1 Items not specified in this document or released on compromise should be inspected with reference to the mutual agreement and limit samples.

11. 注意事项 Precaution for using LCD/LCM

After reliability test, recovery time should be 24 hours minimum. Moreover, functions, performance and appearance shall be free from remarkable deterioration within 50,000 hours(average) under ordinary operating and storage conditions room temperature ($20\pm 8^{\circ}\text{C}$), normal humidity (below 65% RH), and in the area not exposed to direct sun light. Using LCM beyond these conditions will shorten the life time.

Precaution for using LCD/LCM

LCD/LCM is assembled and adjusted with a high degree of precision. Do not attempt to make any alteration or modification. The followings should be noted.

General Precautions:

1. LCD panel is made of glass. Avoid excessive mechanical shock or applying strong pressure onto the surface of display area.
2. The polarizer used on the display surface is easily scratched and damaged. Extreme care should be taken when handling. To clean dust or dirt off the display surface, wipe gently with cotton, or other soft material soaked with isopropyl alcohol, ethyl alcohol or trichlorotrifluoroethane, do not use water, ketone or aromatics and never scrub hard.
3. Do not tamper in any way with the tabs on the metal frame.
4. Do not make any modification on the PCB without consulting TCC.
5. When mounting a LCM, make sure that the PCB is not under any stress such as bending or twisting. Elastomer contacts are very delicate and missing pixels could result from slight dislocation of any of the elements.
6. Avoid pressing on the metal bezel, otherwise the elastomer connector could be deformed and lose contact, resulting in missing pixels and also cause rainbow on the display.
7. Be careful not to touch or swallow liquid crystal that might leak from a damaged cell. Any liquid crystal adheres to skin or clothes, wash it off immediately with soap and water.

Static Electricity Precautions:

1. CMOS-LSI is used for the module circuit; therefore operators should be grounded whenever he/she comes into contact with the module.
2. Do not touch any of the conductive parts such as the LSI pads; the copper leads on the PCB and the interface terminals with any parts of the human body.
3. Do not touch the connection terminals of the display with bare hand; it will cause disconnection or defective insulation of terminals.
4. The modules should be kept in anti-static bags or other containers resistant to static for storage.
5. Only properly grounded soldering irons should be used.
6. If an electric screwdriver is used, it should be grounded and shielded to prevent sparks.
7. The normal static prevention measures should be observed for work clothes and working benches.
8. Since dry air is inductive to static, a relative humidity of 50-60% is recommended.

Soldering Precautions:

1. Soldering should be performed only on the I/O terminals.
2. Use soldering irons with proper grounding and no leakage.
3. Soldering temperature: $350^{\circ}\text{C}\pm 10^{\circ}\text{C}$
4. Soldering time: 3 to 4 second.
5. Use eutectic solder with resin flux filling.

6. If flux is used, the LCD surface should be protected to avoid spattering flux.
7. Flux residue should be removed.

Operation Precautions:

1. The viewing angle can be adjusted by varying the LCD driving voltage V_o .
2. Since applied DC voltage causes electro-chemical reactions, which deteriorate the display, the applied pulse waveform should be a symmetric waveform such that no DC component remains. Be sure to use the specified operating voltage.
3. Driving voltage should be kept within specified range; excess voltage will shorten display life.
4. Response time increases with decrease in temperature.
5. Display color may be affected at temperatures above its operational range.
6. Keep the temperature within the specified range usage and storage. Excessive temperature and humidity could cause polarization degradation, polarizer peel-off or generate bubbles.
7. For long-term storage over 40°C is required, the relative humidity should be kept below 60%, and avoid direct sunlight.

Limited Warranty

TCC LCDs and modules are not consumer products, but may be incorporated by TCC' s customers into consumer products or components thereof, TCC does not warrant that its LCDs and components are fit for any such particular purpose.

1. The liability of TCC is limited to repair or replacement on the terms set forth below. TCC will not be responsible for any subsequent or consequential events or injury or damage to any personnel or user including third party personnel and/or user. Unless otherwise agreed in writing between TCC and the customer, TCC will only replace or repair any of its LCD which is found defective electrically or visually when inspected in accordance with TCC general LCD inspection standard . (Copies available on request)
2. No warranty can be granted if any of the precautions state in handling liquid crystal display above has been disregarded. Broken glass, scratches on polarizer mechanical damages as well as defects that are caused accelerated environment tests are excluded from warranty.
3. In returning the LCD/LCM, they must be properly packaged; there should be detailed description of the failures or defect.